

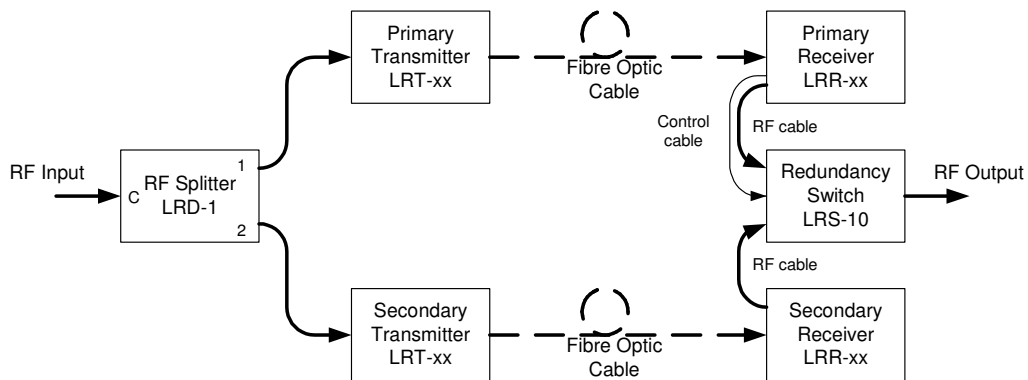

## ViaLite RF SPLITTER APPLICATION EXAMPLE

In a typical configuration, an RF signal is split and fed to two ViaLite transmit modules. These modules are connected via two separate optical fibres to two ViaLite receiver modules. These form the primary and secondary paths. The RF outputs of the primary and secondary receivers are connected to inputs 1 and 2 respectively of the Redundancy Switch module. The RF output on the Common port is fed to the user equipment. A control cable connected between the Redundancy Switch and the primary receiver ensures that the Redundancy Switch selects the Secondary path in the event of a failure in the primary path.



**Figure 1: Typical 1:1 redundancy configuration**

## ViaLite RF SPLITTER SPECIFICATIONS

Parameter	LRD-1	LRD-3	LRD-4
Bandwidth	10MHz – 2.5GHz	10 – 200MHz	10 – 200MHz
Insertion Loss	10 – 100MHz: <3.9dB 100MHz – 1.25GHz: <4.5dB 1.25GHz – 2.5GHz: <4.7dB	10 – 100MHz: <3.9dB 100 – 200MHz: <4.5dB	10 – 100MHz: <3.9dB 100 – 200MHz: <4.5dB
VSWR	<1.8:1	<1.8:1	<1.8:1
Abs. max. RF power input	1W	1W	1W

### Operating Conditions

Operating Temperature	0°C to +40°C
Storage Temperature	-40°C to +70°C

### User Interface

Front panel indicator LEDs	Power – Indicates DC power is applied to the module and that module is plugged in correctly
RF Input/Output	1 – Primary port (input/output) 2 – Secondary port (input/output) C – Common port (output/input)

### Physical Format

Housing Options	Rack Plug-in Module - suitable for Rack Chassis or Plug-in Converter Sleeve
Supply Voltage Rack Plug-in Module	+12Vdc from LRK power supply
Weight Rack plug-in module Plug-in Converter Sleeve	600g 600g + module
Rack Mount Case Suitability	LRK1, LRK2

## Physical Dimensions

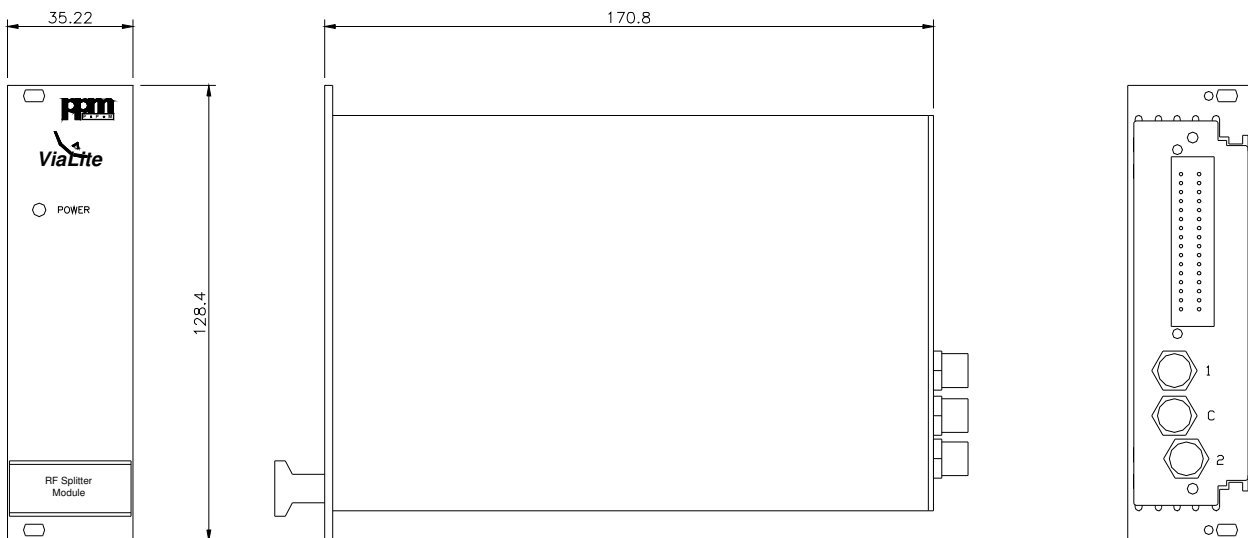

Figure 2: Plug-in Module

## Ordering Information

Part Number	RF Connection
LRD-1	50Ω SMA
LRD-3	75Ω BNC
LRD-4	50Ω BNC

## 19" Rack Case Solutions

Part Number	Description
LRK1	19" Rack Case 3U for desktop or 19" rack installation. Accommodates up to 8 plug-in modules and 2 mains power supplies.
LRK2	19" Rack Case 3U for 19" rack installation. Accommodates up to 8 plug-in modules and 2 mains power supplies.
LPS-M	Main Power Supply plug-in for LRK1 or LRK2.
LPS-R	Reserve Power Supply plug-in for LRK1 or LRK2.
75004	19" Rack Case, 1U for desktop or 19" rack installation, integral power supply, accommodates 3 plug-in modules.

## Accessories

Part Number	Description
LRS-xx	1:1 Redundancy Switch Module. (Substitute 10, 30 or 40 for xx to select connector type. -10 for 50Ω SMA; -30 for 75Ω BNC or -40 for 50Ω BNC)
LAC-1	Alarm Concentrator Transceiver Fibre Optic Link module
73630	SMA Plug to SMA Plug 50Ω RF cable assembly, 0.5m length. Two required for the RF cable connection between LRS-10 Redundancy Switch and primary and secondary modules.
73662	BNC Plug to BNC Plug 75Ω RF cable assembly, 0.5m length. Two required for the RF cable connection between LRS-30 Redundancy Switch and primary and secondary modules.
73661	BNC Plug to BNC Plug 50Ω RF cable assembly, 0.5m length. Two required for the RF cable connection between LRS-40 Redundancy Switch and primary and secondary modules.

## CONTACT US

For further details of this or any other product from PPM, please contact us at:

PPM Ltd, 65 Shrivenham Hundred Business Park, Watchfield, Swindon, Wiltshire, SN6 8TY, UK.

Email: [sales@ppm.co.uk](mailto:sales@ppm.co.uk), Tel.: +44 (0)1793 784389 Fax: +44 (0)1793 784391

Web: [www.vialite.co.uk](http://www.vialite.co.uk) or [www.ppm.co.uk](http://www.ppm.co.uk)